



sankosha®
PRESS AND PROGRESS

Pants Topper

Parts List

DF-740E(REV:2)

Ersatzteile

DF-740E (Moving Parts) REV:2

3DDF740E-V1-051-2

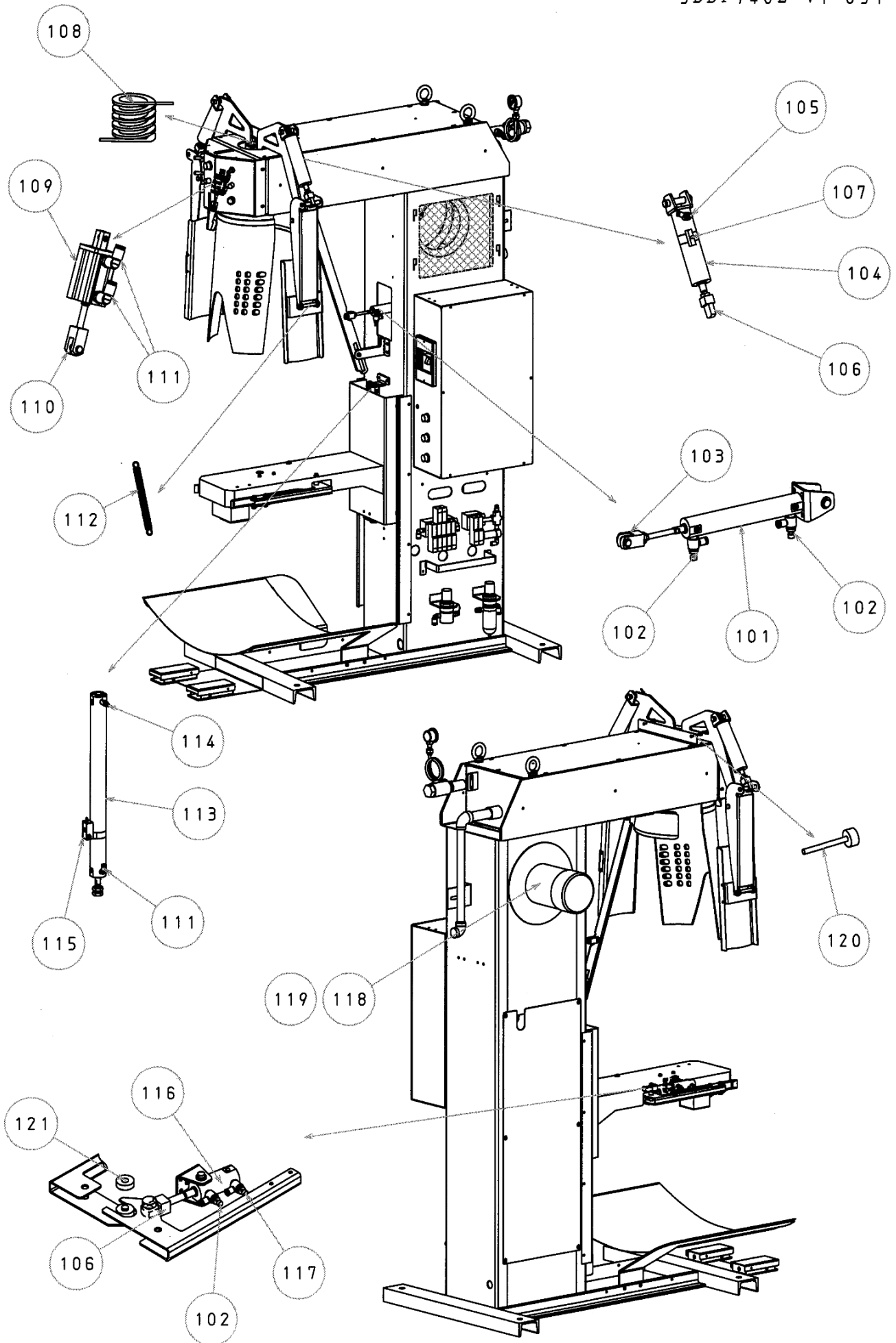

Moving Parts

REV:2

No.	Description	Parts Number	Q'ty	Remark
101	Cylinder	CG1DN20-100	1	Waist Expander
	Cylinder Packing Set	CG1N20-PS	1	
102	Speed Controller	AS2201F-01-04S	3	
103	Knuckle Joint	Y-G02	1	
104	Cylinder	CDG1DN32-50S-B73S	2	L/R Pleater Clamp
	Cylinder Packing Set	CG1N32-PS	2	
105	Speed Controller	AS2211F-01-04S	2	
106	Knuckle Joint	I-G03	3	
107	Cylinder Sensor	D-B73	2	
	Sensor Band	BM1-32	2	
108	Spring	DF730J-V1-236	1	
109	Cylinder	CQ2D16-30DM-XB6	1	Front Clamp
	Cylinder Packing Set	CQ2B16-XB6-PS	1	
110	Knuckle Joint	Y-Z015A	1	
111	Air Joint	KJL04-M5	3	
112	Spring	AUY10-60	2	
113	Cylinder	CDG1BA25-300-B73S	1	Slide
	Cylinder Packing Set	CG1A25-PS	1	
114	Speed Controller	AS1211F-M5-04	1	
115	Cylinder Sensor	D-B73	1	
	Sensor Band	BM1-02	1	
116	Cylinder	CG1TN25-25	1	Cuff Clamp
	Cylinder Packing Set	CG1N25-PS	1	
117	Air Joint	KQ2L04-01S	1	
118	Blower Motor	IK-ECK8-2P 0.2KW-CE	1	
119	Fan	1-195-110 ϕ 11FLSPCC	1	
120	Stopper Bolt	UNST6-40	2	
121	Bearing	6000ZZ	1	

DF-740E (Pneumatic/Switch Parts) REV:2

3DDF740E-V1-052-2

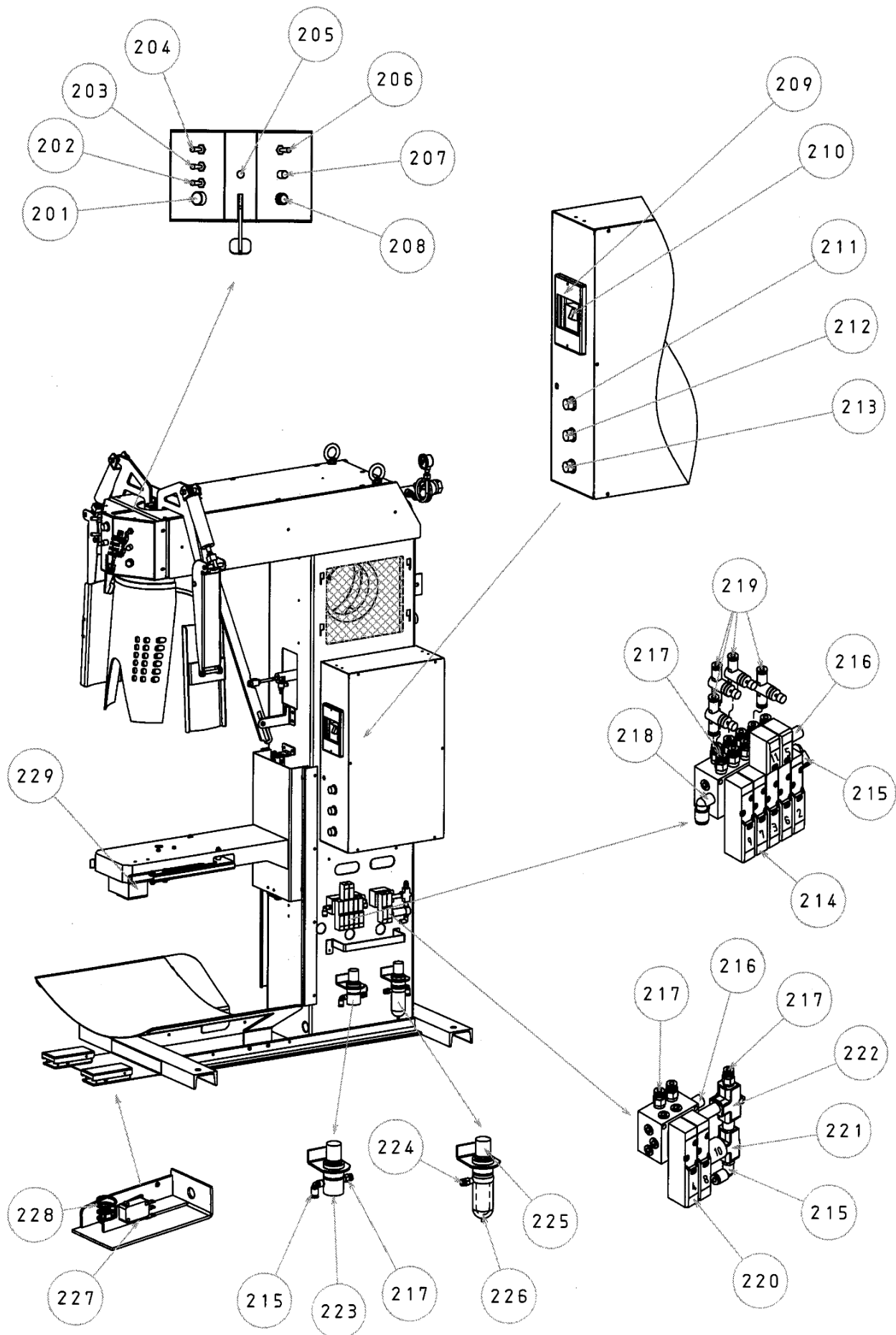

Pneumatic/Switch Parts

REV:2

No.	Description	Parts Number	Q'ty	Remark
201	Push Button Switch	A165-TBM-1	1	Steam
202	Switch	AJ45100F	1	Front Clamp
203	Switch	AJ45100F	1	Pleater Clamp
204	Switch	AJ45100F	1	Dry/Aqua Select
205	Push Button Switch	MS-V2-B22-046F	1	START SW
	Push Button Switch Cap	AT-454G	1	
	Push Button Bracket	AT-9905-53V	1	
206	Switch	AJ45100F	1	Stretch Mode
207	Push Button Switch	AB9252	1	RESET
	Push Button Switch Cap	AB9253L	1	
208	Push Button Switch	A165E-S-02	1	EMG SW
209	Breaker Cover	GV2-CP21	1	
210	Breaker Switch	GV2-ME08	1	Power
211	Volume	RV24YN20S 100KΩ B	1	Steam Timer
212	Volume	RV24YN20S 100KΩ B	1	Dry Timer
213	Volume	RV24YN20S 100KΩ B	1	Aqua Timer
214	Solenoid Valve	PCS245-NB-D24MP	1	No.2: Steam
	Solenoid Valve	PCD345-NB-D24MP	1	No.5,6: Cuff Clamp Up/Down
	Solenoid Valve	PCD345-NB-D24MP	1	No.3,11:Waist Expander/Waist Expander Return
	Solenoid Valve	PCS245-NB-D24MP	1	No.7: Cuff Clamp
	Solenoid Valve	PCS245-NB-D24MP	1	No.9: Front Clamp
	Gasket	PC5-SG	5	
215	Air Joint	KQ2L04-01S	3	
216	Silenser	AS-6	4	
217	Air Joint	KQ2H04-01S	13	
218	Air Joint	KQ2L06-01S	1	
219	Speed Controller	AS2001F-04	4	
220	Solenoid Valve	PCS245-NB-D24MP	1	No.4: Left Pleater Clamp
	Solenoid Valve	PCS245-NB-D24MP	1	No.8: Right Pleater Clamp
	Gasket	PC5-SG	2	
221	Solenoid Valve	VDW21-5G-2-01	1	No.10: Pressure Changing
222	Shuttle Valve	VR1210-01	1	

Pneumatic/Switch Parts

REV:2

No.	Description	Parts Number	Q'ty	Remark
223	Regulator	AR20K-01BE-RY	1	
224	Air Joint	KQ2H06-02S	1	
225	Filter Regulator	AW20-02BCE-R	1	
226	Filter Element	AF20P-060S	1	
	Diaphragm Assembly	AR20P-150AS	1	
	Case Assembly	C2SF	1	
227	Micro Switch	D2VW-01-1M	2	Foot Switch
228	Spring	FP100-105	2	
229	Sensor	PZ-M71	1	

DF-740E (Steam Piping) REV: 2

3DDF740E-V1-053-2

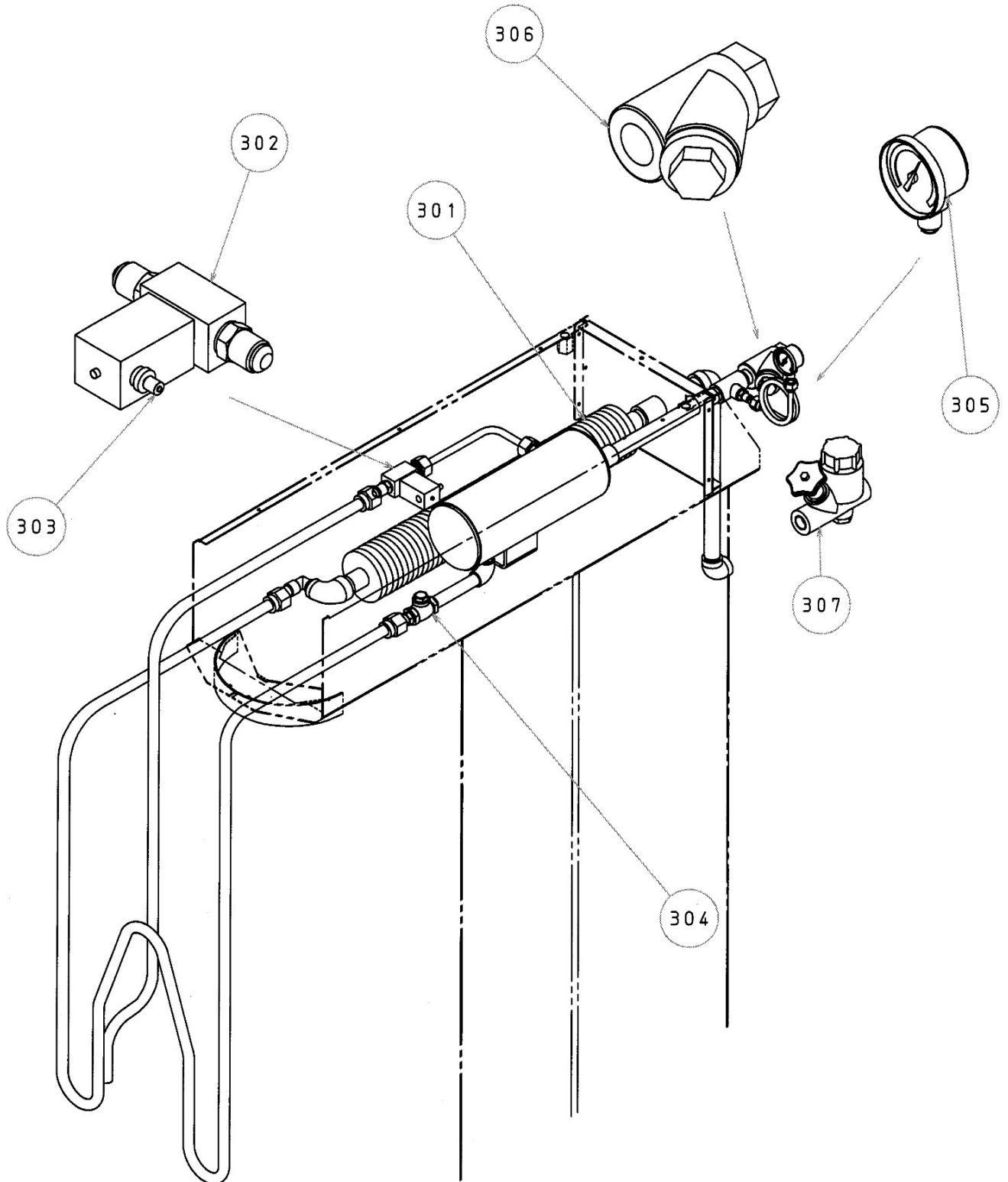

Steam Piping

REV:2

No.	Description	Parts Number	Q'ty	Remark
301	Pipe with Fin	FINPE20A-25-P9.5-L500	1	
302	Steam Valve	VND104D-10A	1	
303	Air Joint	M-01H-4	1	
304	Lift Check	3/8	1	
305	Steam Gauge	AMT7/16 60 ϕ 1.6MPa	1	
306	Y Type Strainer	1/2	1	
307	Steam Trap	YH-15A	1	