



sankosha®
PRESS AND PROGRESS

Single Collar Cuff Press

Parts List

LP-690E(REV:3)

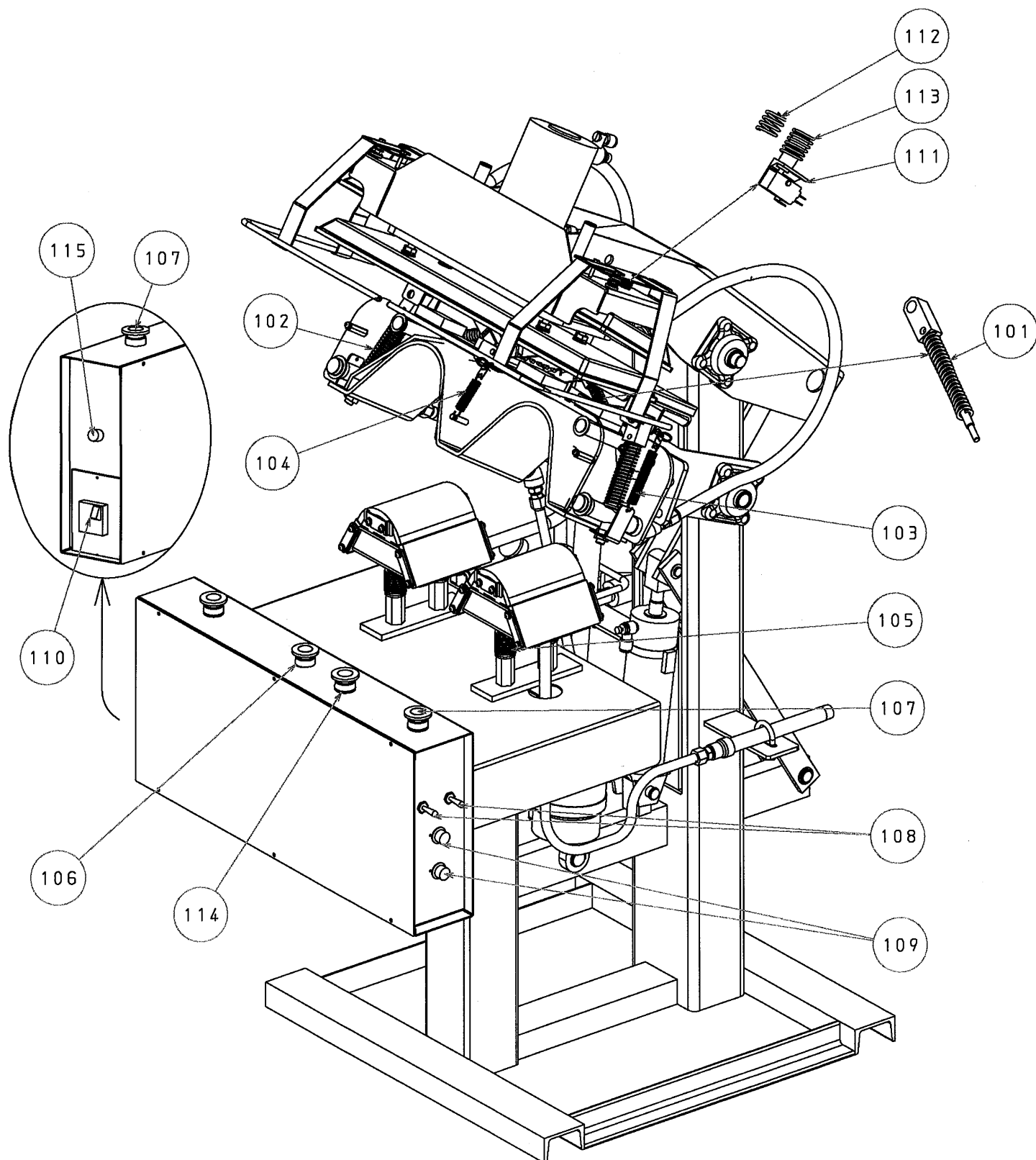

Front Diagram

REV:3

No.	Description	Parts Number	Q'ty	Remark
101	Spring	SWU17-120	2	
102	Spring	SWU26-125	2	
103	Spring	AUY8-60	2	
104	Spring	AUS10-50	2	
105	Spring	SWR31-35	4	
106	Push Button Switch	HW1B-V402R	1	EMG SW(Red)
107	Push Button Switch	HW1B-M110W	2	Start SW L/R(White)
108	Switch	AJ45100F	2	
109	Volume	RV24YN20S 100KΩ B	2	
110	Breaker Switch	GV2-ME08	1	
	Breaker Cover	GV2-CP21	1	
111	Push Button Switch	AB9252	2	GUARD SW
	Push Button Cap	AB9253B	2	
112	Spring	ACC-002	2	Emergency Spring A
113	Spring	ACC-003	2	Emergency Spring B
114	Push Button Switch	HW1B-M110S	1	RESET SW (Blue)
115	Pilot Lamp	BN-2-AC200V	1	

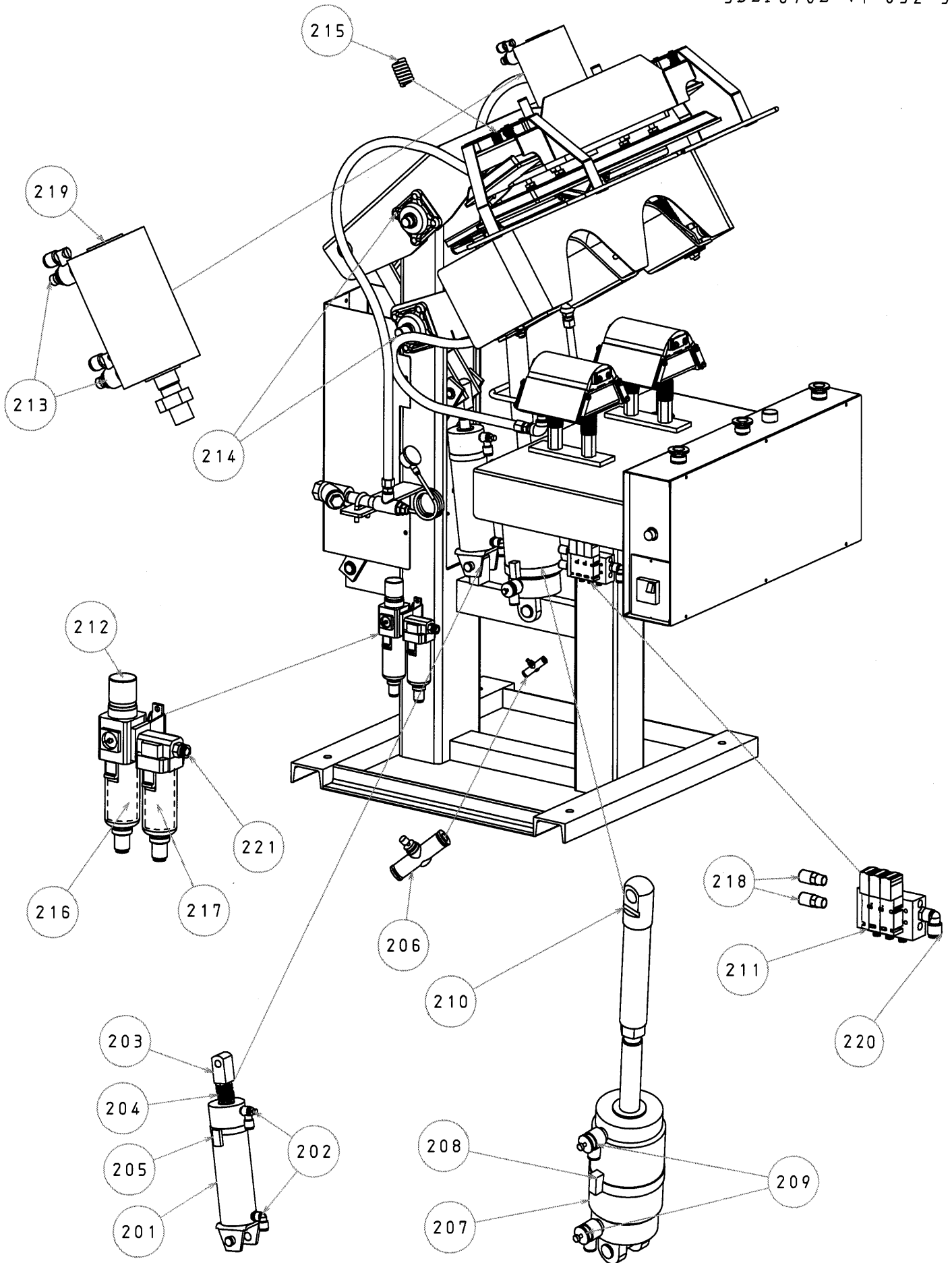

Rear Diagram

REV:3

No.	Description	Parts Number	Q'ty	Remark
201	Cylinder	CDG1DA50-150-B73S	1	
	Cylinder Packing Set	CG1A50-PS	1	
202	Speed Controller	AS3201F-02-10S	2	
203	Knuckle Joint	I-G05	1	
204	Spring	SWU31-50	1	
205	Cylinder Sensor	D-B73	1	
	Sensor Band	BM1-05	1	
206	Speed Controller	AS3001F-10	1	
207	Cylinder	CDG1DA100-100-B53S	1	
	Cylinder Packing Set	CG1A100-PS	1	
208	Cylinder Sensor	D-B53	1	
	Sensor Band	BA-10	1	
209	Speed Controller	AS4201F-04-10S	2	
210	Knuckle Joint	I-G10	1	
211	Solenoid Valve	VQZ3151-5LO-X113	1	No.1: Cuff Press
	Solenoid Valve	VQZ3151-5LO-X113	1	No.2: Upper Press Arm
	Solenoid Valve	VQZ3151-5LO-X113	1	No.3: Press Cylinder
	Gasket Screw Ass'y	VQZ3000-10-1F	3	
	Air Joint Ass'y	VVQ2000-51A-C10	6	
212	Air Combination	AC30D-03DE	1	
213	Speed Controller	AS4301F-04-10S	2	
214	Bearing Unit	UCF204 J	4	
215	Spring	CN630-232	4	
216	Filter	AF30P-060S	1	
	Diaphragm Assembly	AR30P-150AS	1	
	Case Assembly	C3SF	1	
217	Element Assembly	AFM30P-060AS	1	
	Case Assembly	C3SF	1	
218	Silencer	AN203-02	2	
219	Cylinder	CG1BA100-75	1	
	Cylinder Packing Set	CG1A100-PS	1	
220	Air Joint	KQ2L10-03S	1	
221	Air Joint	KQ2H10-03S	1	

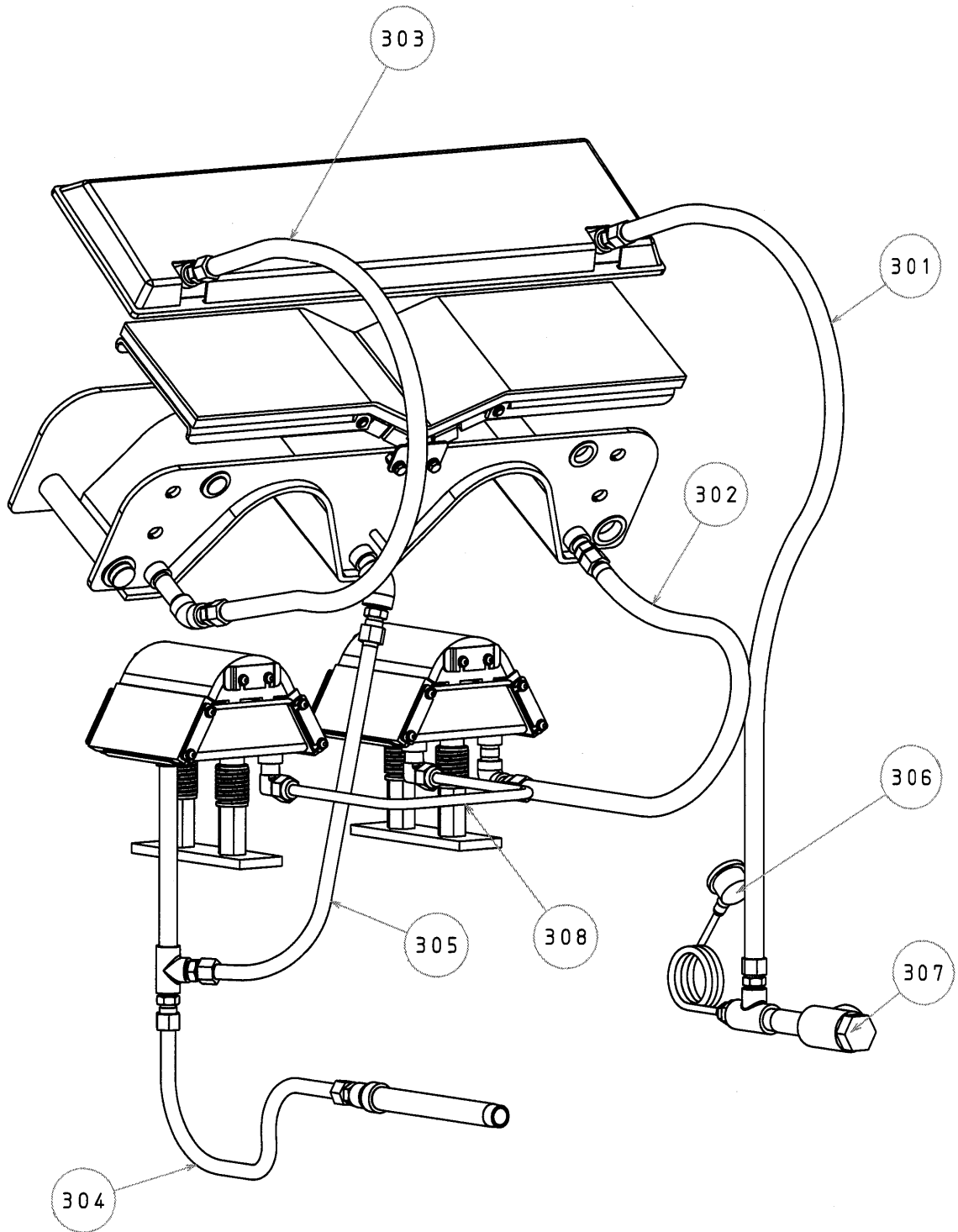

Steam Piping

REV:3

No.	Description	Parts Number	Q'ty	Remark
301	Flex. Hose	3/8*800(Braid)	1	
302	Flex. Hose	3/8*470(Braid)	1	
303	Flex. Hose	3/8*650(Braid)	1	
304	Flex. Hose	3/8*350(Braid)	1	
305	Flex. Hose	3/8*470(Braid)	1	
306	Steam Gauge	AMT7/16 60 ϕ 1.6MPa	1	
307	Y Type Strainer	1/2	1	
308	Pipe	LP690J-V1-174-1	1	No.E080001~E080008
	Flex. Hose	3/8*470(Braid)	1	No.E080009~